

Gasoline Systems

High-pressure pump HDP5



BOSCH

Invented for life

High-pressure pump HDP5



Customer benefits

- ▶ Series experience: high number of customer applications worldwide, compliance to major global fuel specifications
- ▶ Best in class concerning number of possible design variants
- ▶ Local supply of our customers in our international production network
- ▶ Optimized fuel economy due to demand controlled operation
- ▶ Zero evaporation (ZEVAP) capable
- ▶ Low weight (780 g)
- ▶ Easy application to engine packaging

- ▶ **HDP5 evo**
 - Significant noise improvement
 - Increased flow rate

Engines with gasoline direct injection generate the air-fuel mixture directly in the combustion chamber. Only fresh air flows through the open intake valve.

The fuel is injected directly into the combustion chamber using high-pressure injectors. This improves combustion chamber cooling and enables higher engine efficiency due to higher compression, resulting in increased fuel efficiency and torque.

The high-pressure circuit is fed via the high-pressure pump. The high-pressure injectors fitted to the fuel rail meter and atomize the fuel at high pressure and extremely rapidly to provide optimum mixture preparation directly in the combustion chamber.

Task

The fuel is supplied by the electric fuel pump. The high-pressure pump generates the fuel pressure of up to 20 MPa (200 bar) required for high-pressure injection.

The unique pump design features an all stainless steel concept, using a minimum of material input and applying ambitious manufacturing processes for maximum customer benefits.

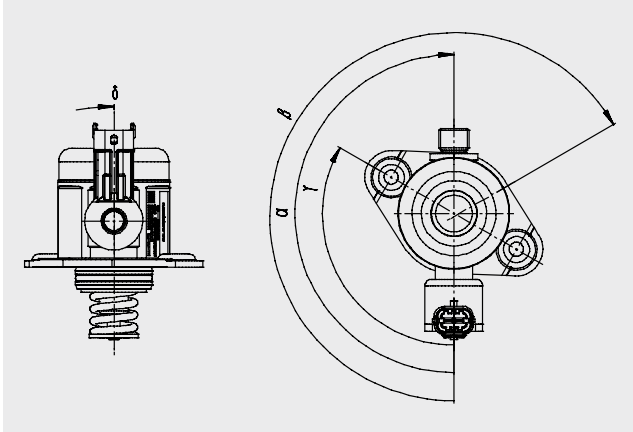
Design**Function**

- ▶ Demand-controlled single piston plug-in pump
- ▶ High flow rate at high speeds
- ▶ Flexible integration concept, hydraulic/electric

Technical features

	HDP5	HDP5 evo
Max. system pressure	20 MPa	20 MPa
Max. delivery quantity	1.12 cm ³ /r _{CAM}	1.2 cm ³ /r _{CAM}
Min. volumetric efficiency	85%	90%
Max. number of strokes (3-way cam)	10,500 min ⁻¹	10,500 min ⁻¹
Pressure relief valve	Integrated	Integrated
Weight	780 g	780 g

Robert Bosch GmbH
Gasoline Systems

Postfach 300240
70442 Stuttgart
Deutschland

www.bosch-automotivetechnology.com

Printed in Germany
292000P146-C/CCA-201309-En