

Servolectric® Electromechanical steering system for a dynamic driving experience and highly automated functions



BOSCH

Invented for life

Connected mobility

Automated driving

Powertrain and electrification



Power on demand

The Servolectric® electric power steering system consumes energy only when the driver actually turns the steering wheel. In the most frequent situation - travelling in a straight line - the energy used tends to zero.

Up to
-10% **20%**

fuel consumption and CO₂ emissions. Compared with hydraulic steering system, urban traffic only, passenger car with two-litre gasoline engine, average fuel consumption of 7.7 l/100 km.

weight reduction compared with conventional power steering systems (in the compact class). Servolectric® achieves this saving in part by reducing the number of components of the steering system.

Over **50 million**

passenger cars with electric power steering are already **on the road worldwide.**

From comfortable to sporty and dynamic driving

Examples of characteristics of steering system matching on vehicles

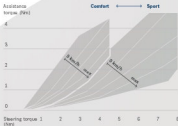

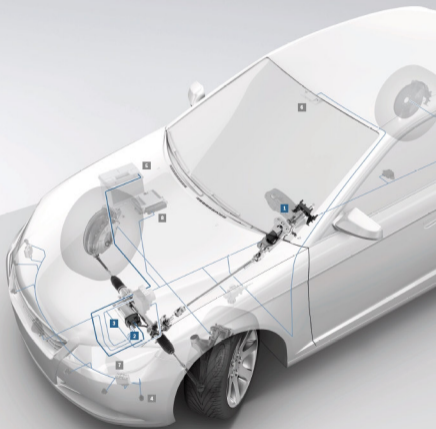

- 1** steering angle sensor
- 2** Electronic control unit
- 3** Electric motor
- Data flow
- Energy flow

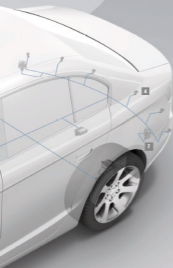

- 4 Ultrasonic sensors
- 5 Battery
- 6 Stereo video camera
- 7 Radar
- 8 Engine control unit

System benefits

- ▶ Speed-sensitive steering assistance
- ▶ High efficiency and low system friction
- ▶ Improved steering feel and steering performance
- ▶ Various drive modes can be implemented in a vehicle
- ▶ Optimal usage of installation space through three basic types for all passenger car classes and light commercial vehicles
- ▶ Flexible packaging
- ▶ Maintenance-free

Connected mobility

- ▶ Connection with other components (e.g. battery, camera, radar) as well as vehicle control unit
- ▶ Improved safety, comfort, and convenience thanks to the ability to implement innovative driver assistance systems (e.g. Evasive Steering Support, Traffic Jam Assist, Parking Maneuver Assist)

Automated driving

- ▶ Key technology for implementing automated driving
- ▶ Integrating the ECU into the on-board power supply of the vehicle paves the way for automated driving functions

Powertrain and electrification

- ▶ One of the key technologies for powertrain electrification
- ▶ Significant reduction in fuel consumption and CO₂ emissions thanks to power-on-demand principle

Servolectric®

Connected driving with power steering

Intelligent steering assistance The electromechanical power steering Servolectric® controls and assists vehicle steering using an intelligently controlled electric motor. Based on the steering signal recorded by the torque sensor, the ECU calculates the optimum steering assistance and forwards this information to the electric motor, which provides the necessary force.

Passenger cars and light commercial vehicles With just three installation versions, the Servolectric® covers the requirements of all passenger car classes and even light commercial vehicles. The versions transfer the motor torque in different ways. In the paraxial version, the torque is transmitted to the servo gear system (toothed-belt drive and recirculating ball gear) via a toothed disc located on the motor shaft. In the twin pinion and steering column versions, the torque is transmitted to the worm gear by means of a coupling.

Connected systems In an electric power steering system, power assistance is calculated not just from steering torque on the steering wheel, but also by taking many additional vehicle parameters into account. To this end, Robert Bosch Automotive Steering has developed an intelligent control design that includes the ECU as well as the innovative software. That provides the basis for networking with other vehicle systems and components.

Automated functions With its integration of the ECU into the vehicle electrical system, Servolectric® offers considerable potential for implementing assistance functions. Thanks to its numerous connectivity options, it is also the key technology for more extensive automated functions and the fully automated vehicle of the future.

Standard values of steering rack force and mechanical performance for all vehicle classes

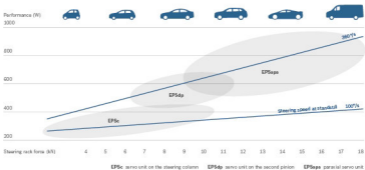

Servolectric® electric power steering system

Servo unit on the steering column



BOSCH
Invented for life

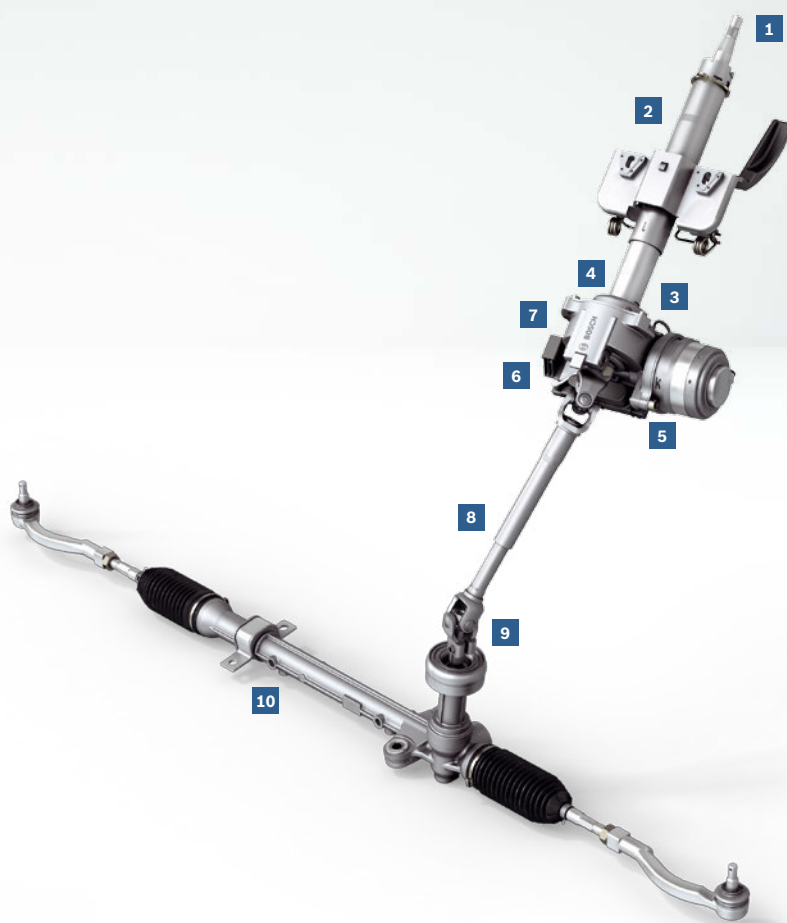

Product benefits

- ▶ Ideal electric power steering solution for vehicles up to lower mid-range
- ▶ Low weight and minimal space requirements
- ▶ The steering column and servo unit are delivered to the production line ready to install

- 1** Serrations for steering wheel
- 2** Upper steering column
- 3** Sensor cable
- 4** Torque sensor
- 5** Electric motor
- 6** Electronic control unit
- 7** Worm gear
- 8** Intermediate steering shaft
- 9** Input shaft connection
- 10** Mechanical rack and pinion steering

–90 %

Energy consumption*

* compared with hydraulic steering, urban traffic only, passenger car with two-liter gasoline engine, average fuel consumption of 7.7l/100 km

1,000 kg

Servolectric® with servo unit on the steering column is configured up to this **steering axle load** and is therefore suitable for subcompact and compact cars as well as mid-size vehicles.

–10 %

Fuel consumption and CO₂ emissions*

Task The Servolectric® electric power steering system controls and assists the vehicle steering with the aid of an electronically controlled electric motor. Bosch developed Servolectric® with the servo unit on the steering column specifically for vehicles with lower steering effort. It is therefore the ideal electric power steering solution in the entry-level segment and is suitable for use in compact and subcompact cars as well as in mid-size vehicles.

Function The servo unit and its electronic control unit are integrated in the steering column. They are connected to the mechanical rack and pinion steering gear via the intermediate shaft with universal joints. The sensors and torsion bar are located next to the worm gear. The torque produced by the electric motor is converted, via a worm gear, into an assistance torque and transmitted to the intermediate shaft. The ideal base for these steering variants is the mechanical rack and pinion steering. Rigidity, good efficiency, and compact lightweight design are the benefits of this well-proven component of which millions have been produced. The ratio of the rack and pinion steering can be

either constant or variable. Software developed by Bosch allows the electric power steering system to be programmed to the customer's own requirements. As such, a steering system with the same hardware components can be adapted for various types of application.

Variants To achieve appropriate adaptation of the electric power steering system to the particular vehicle, modular servo units are available for different performance requirements. Another option is to separate the electronic control unit from the servo unit and position it in a different location if necessary for packaging reasons.

Configuration of the mechanical rack and pinion steering:

- 1 Bellows
- 2 Steering rack
- 3 Housing
- 4 Drive pinion
- 5 Input shaft connection
- 6 Tie rod

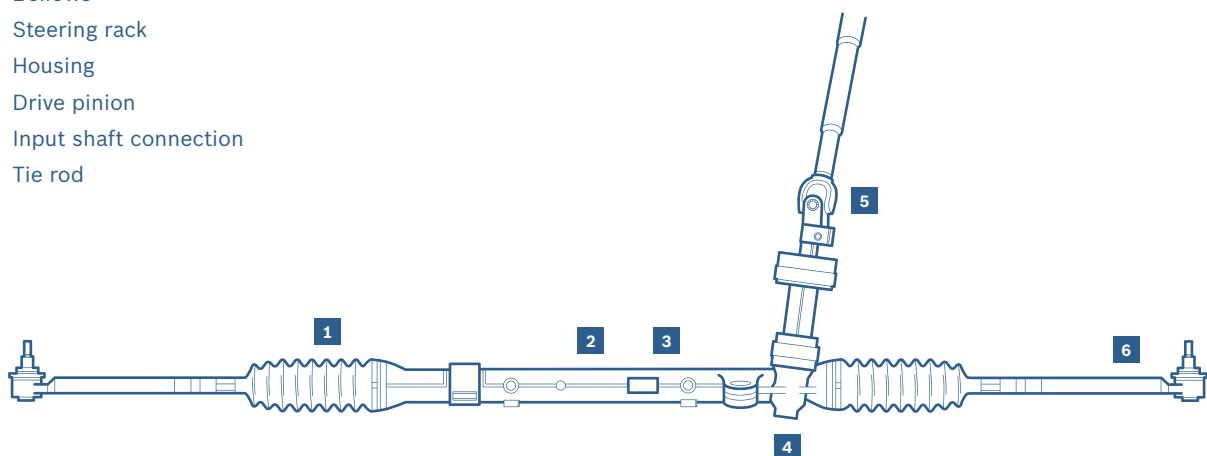

Servolectric® electric power steering system

Servo unit on a second pinion



BOSCH
Invented for life

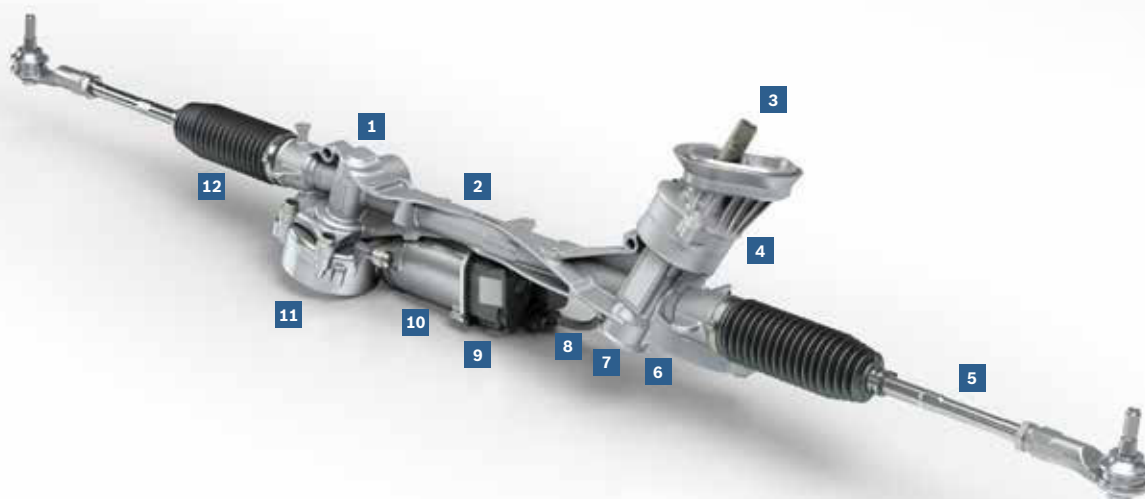

Product benefits

- ▶ Ideal electric power steering solution for mid-size cars
- ▶ Support for performance-optimized configuration
- ▶ Outstanding crash safety
- ▶ Highly flexible packaging
- ▶ Robust worm gear transfers the assistance torque throughout the steering gear's entire service life

- 1** Drive pinion (second pinion)
- 2** Housing
- 3** Input shaft connection
- 4** Torque sensor
- 5** Tie rod
- 6** Yoke
- 7** Steering pinion
- 8** Sensor cable
- 9** Electronic control unit
- 10** Electric motor
- 11** Worm gear
- 12** Bellows

-90 %

Energy consumption*

* compared with hydraulic steering, urban traffic only, passenger car with two-liter gasoline engine, average fuel consumption of 7.7l/100 km

1,200 kg

Servolectric® with the servo unit on a second pinion is configured up to this **steering axle load**, making it suitable for mid-size vehicles.

-10 %

Fuel consumption and CO₂ emissions*

Task The Servolectric® electric power steering system controls and assists the vehicle steering with the aid of an electronically controlled electric motor. Servolectric® with the servo unit on a second pinion provides the ideal electric power steering solution for mid-size vehicles.

Function Installing the servo unit on the second pinion allows the physical separation of the sensor and the drive unit. The drive pinion ratio's independence from the steering ratio paves the way for performance-optimized configuration. System performance is increased by 10 to 15 percent. And outstanding crash safety is guaranteed thanks to optimum use of the available installation space. By allowing the servo unit to rotate 360 degrees about the axes of the rack and the drive pinion using a suitable tuned worm gear, the position of the servo unit can be defined to fit the particular application.

The function of the sturdy worm gear is to convert the torque provided by the electric motor into assistance torque and to transmit that torque to the steering rack. The requirements made in the process on performance and comfort are exacting. To meet these requirements, the teeth of the worm and helical gear must remain in mesh without backlash throughout the steering gear's entire service life. To this end, a specially developed spring damper element is used, providing optimum spring load to the worm in any driving situation. An innovative fixed bearing is fitted to ensure that the worm can move as necessary.

In unusual driving situations and in case of abuse, the worm gear is subjected to extreme loads. To prevent the worm gear from being damaged, in those rare cases, an overload safety device is provided between the helical gear and drive pinion. This provides a defined limit to the torque that can be transmitted.

Software developed by Bosch allows the electric power steering system to be programmed to the customer's own requirements. As such, a steering system with the same hardware components can be adapted for various types of application.

Configuration of the worm gear:

- 1 Helical gear
- 2 Spring damper element
- 3 Worm
- 4 Drive pinion
- 5 Housing

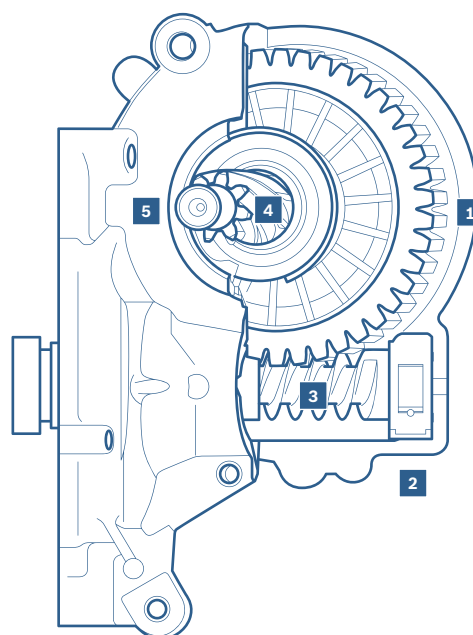

Servolectric® electric power steering system

Paraxial servo unit



BOSCH
Invented for life

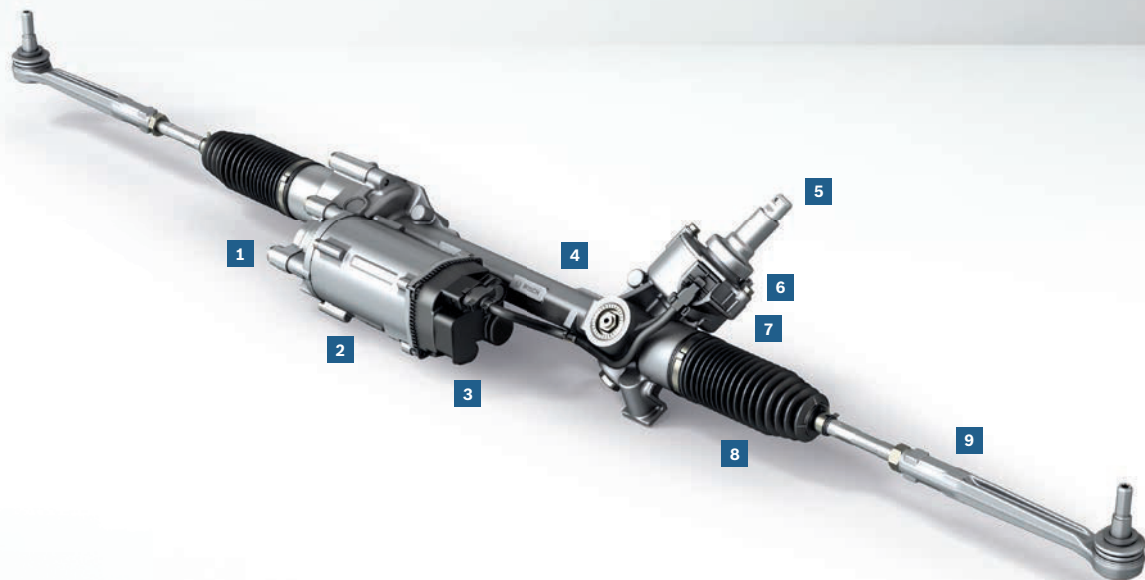

Product benefits

- ▶ Ideal electric power steering system for luxury-class vehicles, sports cars, SUVs, and light commercial vehicles
- ▶ High efficiency and low system friction

- 1** Recirculating ball gear
- 2** Motor
- 3** Control unit
- 4** Housing
- 5** Input shaft connection
- 6** Sensor unit
- 7** Steering pinion
- 8** Bellows
- 9** Tie rod

–90 %

Energy consumption*

* compared with hydraulic steering, urban traffic only, passenger car with two-liter gasoline engine, average fuel consumption of 7.7l/100 km

1,600 kg

Servolectric® with paraxial servo unit is configured up to this **steering axle load** and is therefore also suitable for SUVs and light commercial vehicles.

–10 %

Fuel consumption and CO₂ emissions*

Task The Servolectric® electric power steering system controls and assists the vehicle steering with the aid of an electronically controlled electric motor. Servolectric® with paraxial servo unit provides the ideal electric power steering solution for vehicles with very high steering effort – from the dynamic sports car, the upper mid-size, and luxury class, to SUVs and light commercial vehicles.

Function To transform the rotational movement of the steering wheel into a linear movement of the steering rack, the Servolectric® with paraxial drive variant uses a drive concept consisting of toothed-belt drive and recirculating ball gear. Both drive stages are highly efficient. The recirculating ball gear is a system in which the ball chain is returned through a channel integrated in the ball recirculating nut. The recirculating ball gear generates minimal noise during operation. The slip-free toothed belt is also extremely quiet and transmits high levels of torque safely.

Due to the combination of recirculating ball gear and toothed-belt drive, Servolectric® with paraxial drive is ideally suited for varying customer requirements. The flexible positioning options of the servo unit enable the best-possible use of the installation space available in the vehicle.

Software developed by Bosch allows the electric power steering system to be programmed to the customer's own requirements. As such, a steering system with the same hardware components can be adapted for various types of application.

Configuration of the recirculating ball gear:

- 1 Steering rack
- 2 Ball recirculating nut
- 3 Ball chain
- 4 Ball return channel
- 5 Toothed disc

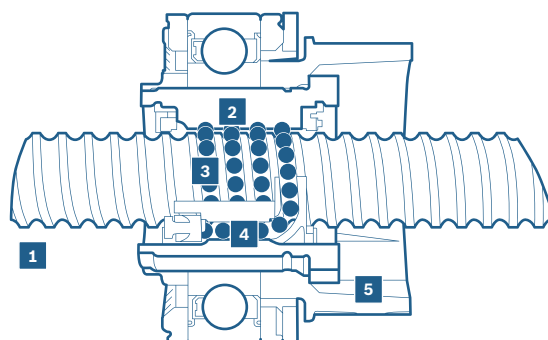

Servolectric® electric power steering system

Steering motors



BOSCH
Invented for life

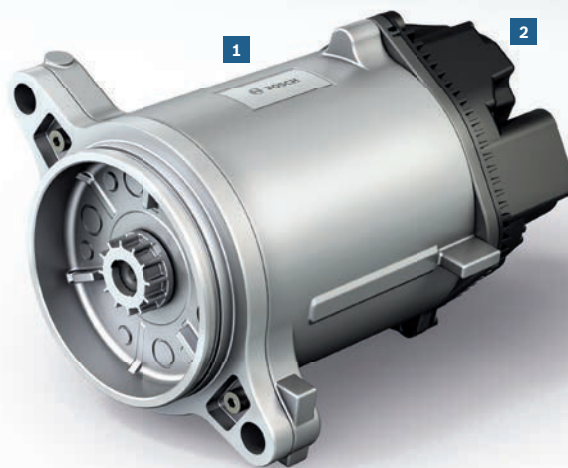

Product benefits

- ▶ Highly precise steering assistance
- ▶ Highly efficient electric motor thanks to state-of-the-art materials
- ▶ Extremely compact size
- ▶ Optimized noise performance and low torque ripple of the electric motor
- ▶ Optimal adaptation to customer requirements thanks to graded output ratings and modular design of the powerpack

- 1** Housing
- 2** Control unit

2–8 Nm

The **available torque** covers the requirements of all passenger cars and light commercial vehicles.

400–800 W

Power output available depending on the vehicle class for the graded variants of the steering motors.

Task Electronic control and steering assistance that uses Servolectric® simply requires an easy-to-use medium: electric current. The electric motor provides the universally available, reliable, and economical energy supply. The newly developed generation of brushless electric motors provides the assistance calculated by the Servolectric® electronic control unit with high precision and in accordance with the particular driving conditions.

Function Depending on the variant, the motor torque is transferred in various ways. On the paraxial variant the torque is transmitted to the servo gear system (toothed-belt drive and recirculating ball gear) via a toothed disc located on the motor shaft. On the Servolectric® steering column variant and the twin pinion variant, the torque is transmitted to the worm gear by means of a coupling.

Variants The same motor and stator components are used for all Servolectric® steering variants. Various motor designs in the ratings 2 Nm to 8 Nm can be produced by modifying the interfaces and housings.

Configuration of the electric motor for the paraxial steering variant:

- 1 Signal input
- 2 Housing
- 3 Spring washer
- 4 O-Ring

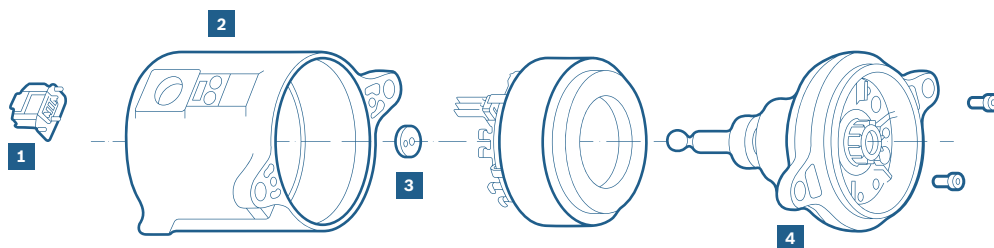

Servolectric® electric power steering system

Electronic control unit



BOSCH
Invented for life



Product benefits

- ▶ Intelligent, rapid calculation of steering assistance and corrections within milliseconds
- ▶ Facilitates implementation of innovative driver assistance systems
- ▶ Integration into vehicle electrical system via CAN bus or FlexRay™
- ▶ Fully integrated and hermetically sealed unit

- 1** Control electronics with heat sink
- 2** Plug contacts

32-Bit- microprocessor

New assistance functions that network with the vehicle electrical system

Flash memory

Task The electronic control unit (ECU) is the intelligent heart of the Servolectric® electric power steering system. On the basis of the steering signal recorded by the torque sensor, the ECU calculates the optimum assistance and forwards this information to the electric motor. The ECU also processes a range of vehicle parameters and calculates necessary steering corrections within milliseconds.

Function The ECU links the electric power steering with the vehicle electrical system and with various other vehicle components. This means the electric power steering can access parameters such as speed, steering angle, wheel speed, and yaw rate. On this basis, the ECU can constantly calculate the vehicle's longitudinal and lateral guidance as well as the optimum steering assistance, and intervene to carry out corrections in emergencies with the aid of driver assistance systems. The manufacturer decides which driver assistance systems are used in the vehicle and what their role is. This opens up a way to influence the vehicle's lateral guidance in hazardous situations using the electric power steering, thus preventing accidents or mitigating their effects.

Technical characteristics

Processor	32-bit microprocessor
Storage technology	Flash
Connectivity options	CAN-Bus, FlexRay™
Current	60 to 110 A

How the control unit works:

- 1 Steering signal is recorded by torque sensor and forwarded to the control unit
- 2 Optimum assistance and motor control calculated

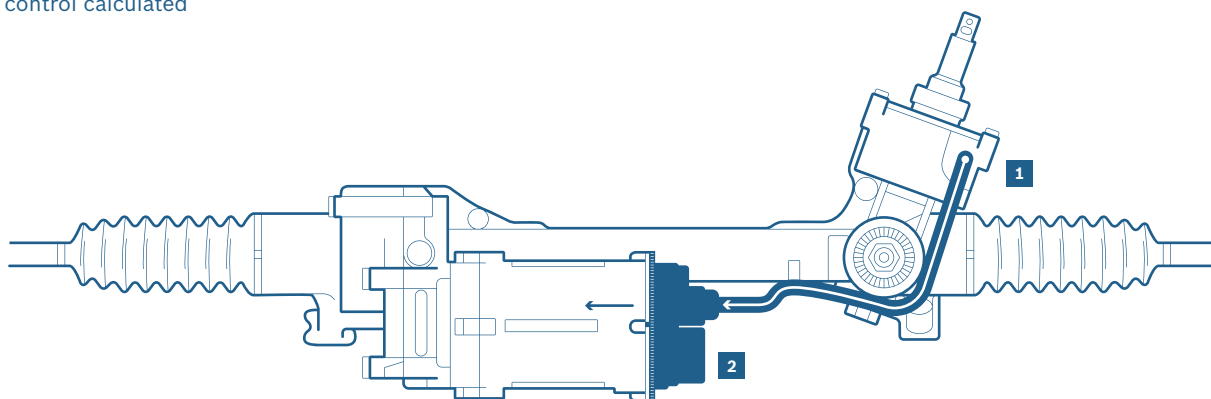

Servolectric® electric power steering system

Torque sensor



BOSCH
Invented for life

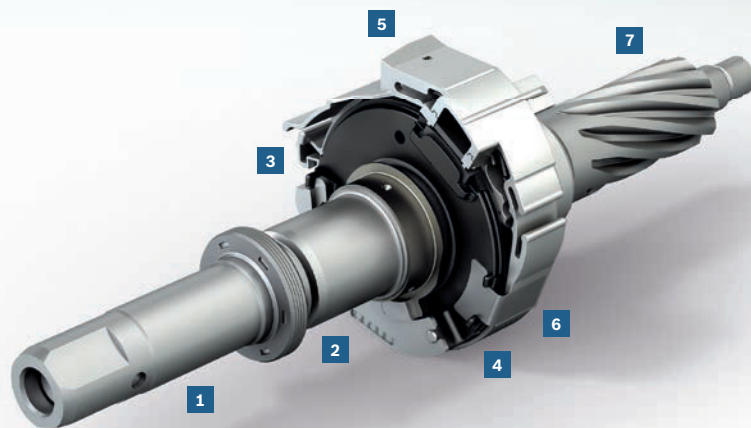

Product benefits

- ▶ Highly precise measurement of the steering torque for exacting safety requirements placed on electric steering systems
- ▶ Extremely robust digital interface to the electric steering system's ECU

- 1 Input shaft
- 2 Pole wheel
- 3 Sensor module
- 4 Index sensor (optional)
- 5 Clock spring
- 6 Index magnet (optional)
- 7 Steering pinion

0,1 Nm

The ECU together with the torque sensor can calculate the steering torque on the basis of sensor data with this **precision**.

-40 °C to +125 °C

The torque sensor in the electric power steering system works absolutely reliably over this **temperature range**.

Task The torque sensor in the Servolectric® electric power steering system measures the torque the driver applies to the steering wheel. Based on this data, the electronic control unit calculates the steering assistance which the electric motor needs to apply.

Function The sensor sits on the steering pinion. A pole wheel is fitted on the input shaft, which is connected to the steering pinion by means of the torsion bar. If the driver applies torque on the steering wheel, the torsion bar is rotated and, in turn, the magnet relative to the sensor. The sensor consists of magnetoresistive elements whose resistance changes as the field direction changes. The sensor's measuring range lies between +/-10Nm. A mechanical angle limiter prevents the torsion bar from being overloaded where higher steering torques are applied.

Variants Optionally, an index magnet and an index sensor can be fitted to the torque sensor. The index sensor delivers a signal to the ECU for each full turn of the steering wheel.

Technical characteristics

Measurement principle	Magnetoresistive effect
Interface	PAS – robust digital two-wire current interface
Signal transmission	With clock spring
Measuring range	+/-10Nm
Temperature range	-40° to +125 °C
Accuracy	0,1Nm at 2Nm/°
Torsion bar stiffness	2,0 to 2,5 Nm/°
Calibration function	Data is stored in the sensor
Steering angle	Can be displayed as an option with index extension

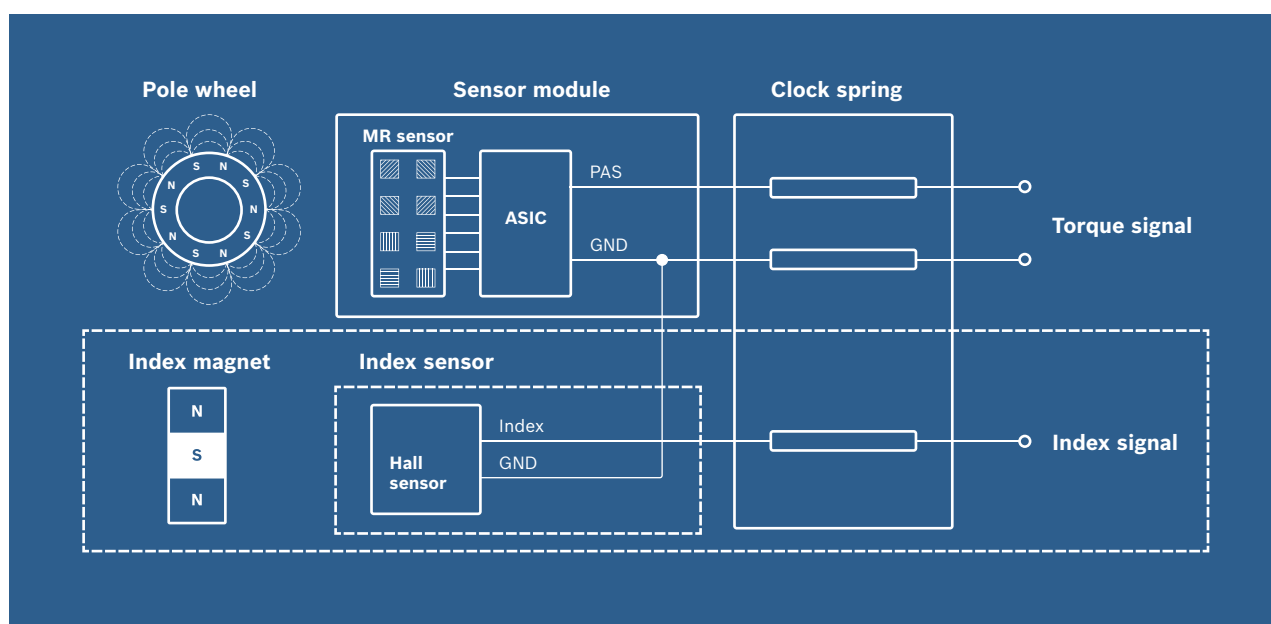

Automotive competence from a single source

Bosch – your partner for steering systems



20 locations
on four continents

Global presence Robert Bosch Automotive Steering (formerly ZF Lenksysteme) has 20 locations in eight countries. This ensures we have a global presence in the core automotive markets – in Europe and Asia as well as in the Americas. Worldwide, more than 13,000 associates are involved in the development and production of steering systems. Including 1,500 specialists devoted to finding the perfect steering feel.



System provider
with holistic expertise

System and network competence We offer our customers not just components, but also complete, fine-tuned systems which benefit from our holistic expert know-how in the area of steering systems. As part of the Bosch Mobility Solutions business sector, we are also able to network our solutions in-house with the entire range of vehicle systems, such as engine management or driver assistance systems, to provide tangible benefits.



Staying on track for the long haul
and pulling together

Long-term partnership As the world's leading manufacturer of steering systems, Robert Bosch Automotive Steering is an experienced, capable partner for the automotive industry. Our customers have come to value us because we are trustworthy, reliable and professional. We support the customer throughout the entire vehicle lifecycle – from the joint development project through to the global supply of spare parts.



Our core competence
is the perfect steering feel

Comprehensive portfolio Whether you're looking for innovative steering systems for passenger cars and commercial vehicles, steering columns with memory function, or fuel-efficient steering pumps – Robert Bosch Automotive Steering offers a comprehensive steering systems portfolio of competitive solutions and products for many vehicle classes. Thanks to our decades of experience and expertise, our core competences in steering are valued throughout the global automotive industry.



Reliable and robust
from the highway to the race track

Ensuring quality and reliability Manufacturers all around the world trust the tried-and-tested quality of our steering systems, components, and services. From the endless highway and the urban rush-hour to top performance on the racetrack, our products are in use every day and have demonstrated their quality and robustness millions of times over. Numerous awards from our customers, such as the Volvo Quality through Excellence Award, the VW Group Award, or the Tesla Motors Supplier Award similarly attest to this trust.



Singled out
for technical progress

Innovation driver and technology leader Robert Bosch Automotive Steering sets the pace and course in steering systems for passenger cars and commercial vehicles. We are actively helping shape technological progress with our innovative products. The awards for our products, including the German Industry Innovation Award, bear testimony to these achievements, as do our customers' high levels of satisfaction.